

# **‘Inverted’ imperatives\***

Laura Rupp

Imperatives in English occur with a *Subject do(n't)* order as well as with the reverse order *do(n't) Subject*. With reference to interrogatives, studies of imperatives quite generally assume that the surface inverted order similarly arises when *do(n't)* is placed in C above the subject in SpecIP. I present evidence that the (non-) inverted orders rather occur because there is variation in the position of subjects in imperatives. This analysis is shown to account for a cluster of other properties that characterise the imperative. The syntax of imperatives is relevant to a number of current issues in syntactic theory, such as the status of the EPP, the motivation for Move and the apparent problem of optional displacement.

## **1. Introduction: the puzzle**

The examples in (1) and (2) show that negative imperatives closely resemble interrogative clauses to the extent that they may be expressed with an inverted *don't Subject* order.

- (1) Didn't you try again?
- (2) Don't you try again!

The standard assumption for English is that the surface position of subjects is fixed in SpecIP, whilst inverted orders in interrogatives arise from I-to-C movement (or: Subject-Auxiliary Inversion) as a result of which auxiliaries like *don't* show up in front of the subject.<sup>1</sup> Given the word order correspondence between (1) and (2) above, then, the minimal hypothesis is that essentially the same analysis carries over to negative imperatives (Davies 1986, Potsdam 1998, Han 2000, among others).

Straightforward as things might seem, an analysis along these lines faces the problem that this is as far as the similarity goes. Consider first the case of negative interrogative clauses. Assuming that the bound morpheme *n't* and the free element *not* are both independent NEG heads of a NEGP (on the model of Pollock 1989), negative interrogatives can be derived in the following two ways. Alongside the derivation of (3a) in which the auxiliary *do* carries *n't* along on its way to C, the alternative is to use *not* and raise *do* alone, as illustrated in (3b).

- (3) a. Didn't you try again?  
 b. Did you not try again?

Hence, if imperatives were formed in an interrogative-type fashion, we would expect there to be imperative equivalents with *not*. This is not the case:

- (4) \*Do you not try again!

Another apparent difference between the two types of sentence is that *do* is obligatory in positive interrogatives, but ungrammatical in affirmative imperatives.

- (5) a. Did you try again?  
 b. \*Do you try again!

Different suggestions as to how to interpret these contrasts have been made in the past. Without discussing previous accounts in any great detail, there is quite general agreement that the specifics of imperatives relate to the element *don't* in this construction. For example, Zhang (1990) and Henry (1995) suspect that in imperatives *don't* is not the auxiliary *do* but might best be analysed as a lexically unitary negative imperative particle (an idea originally put forward by Cohen 1976).<sup>2</sup> As indicated in (6) below, Henry (1995) in addition posits with others (Beukema and Coopmans 1989, Zanuttini 1991) that imperative *don't* is generated directly in COMP. This assumption accounts for the inverted word order in imperatives and it excludes *Subject don't* sequences, which have often been judged impossible.

- (6) [CP [C Don't][IP you [I I][VP [v try] again]]!]

In this contribution, I will present a new way of looking at the matter. I envisage that rather than an idiosyncrasy of *don't*, the determinant factor in the syntax of imperatives is the particular distribution of subjects.

## 2. The status of *don't* in imperatives

To decide whether or not the element *don't* is special in any sense in imperatives, we shall first examine the possibility that it is in fact none other than the dummy auxiliary. As a starting point, I will briefly review the configurations in which the auxiliary *do* occurs in other clause types.

By the Economy Principle (Chomsky 1989 and later), the English-particular rule of *do*-insertion only operates as a 'last resort'. That is, *do* serves to satisfy a grammatical requirement, such as feature checking, which cannot

be met otherwise. For interrogatives, it is said that *do*-insertion must apply invariably to check off some ‘strong’ verbal feature of C because verbs are immobile in the English overt syntax and thus unable to reach C before Spell-Out. This situation is shown in (7).

- (7) a. \*Criticised she (not) him?  
 b. Did she (not) criticise him?  
 [CP [C Did<sub>i</sub>][IP she [I t<sub>i</sub>] (not) [VP [V criticise] him]]]?

In finite declarative clauses, by contrast, *do* is confined to negative and emphatic structures, which implies that its use there is not driven by a strong feature. (8a-d) are illustrative examples.

- (8) a. Ivy (always) criticises him.  
 b. \*Ivy does criticise him.  
 c. Ivy doesn’t / does not criticise him.  
 d. Ivy DOES criticise him.

Pollock (1989) and Laka (1990), respectively, have proposed that sentential negation and emphatic affirmation are functional heads in their own right, situated between V and INFL. In the framework of Chomsky (1995: ch. 4), the reason why *do* is used in the presence of these heads (subsumed under the label  $\Sigma$  in (9) below) is that they block covert feature raising from V to INFL.

- (9) [IP Ivy [I [3S]][ $\Sigma$ P [ $\Sigma$  n’t / not / EMPH][VP [V criticises] him]]]  
 \_\_\_\_\_ × \_\_\_\_\_ [3S.PRES.IND]

In consequence, some non-interpretable features (e.g. verbal  $\phi$ -features) fail to be checked, but these cannot remain in the derivation, and the only way to save the derivation from crashing at LF is to insert *do* in INFL. In non-emphatic declaratives, on the other hand, there is nothing stopping this V-to-I feature raising process, rendering *do*-insertion unnecessary and hence impossible.

Observe now that *do(n’t)* occurs in essentially the same environments in imperatives as it does in finite declarative clauses.

- (10) a. Support him!  
 You support him!  
 b. \*Do support him!  
 \*Do you support him!  
 c. Don’t criticise him!  
 Don’t you criticise him!

- d. Do not criticise him!  
\*Do you not criticise him!
- e. DO support him!  
(If the others won't,) DO AT LEAST YOU support him!

This patterning suggests that in imperatives, too, *don't* is simply the *do* of Last Resort *do*-insertion. (Potsdam 1998 comes to the same conclusion.) The examples in (10d,e) show that *do* is certainly not uniformly absent from imperatives. It appears in emphatic imperatives, and also co-occurs with *not* if the subject is covert. I see no good reason to assume that the status of *don't* in imperatives is different from elsewhere. In section 6, I will address the question of why (*do*) *not* is not fully available in imperative structures with an overt subject.

### 3. The syntax of *do(n't)* in imperatives

In an attempt to come to terms with the contradictory behaviour of imperatives in comparison with interrogative clauses, proponents of 'imperative *do(n't)*-analyses' have suggested that *do(n't)* is not first inserted into INFL and then raised to COMP, but gets generated straight under the C-node. The motivation which Zanuttini (1991) offers for this unusual procedure is that in imperatives, INFL is an 'inert' head in the sense that it is void of typical inflectional material such as agreement features, leaving nothing for *do(n't)* to check there. That imperative INFL is inert is reflected, the claim goes, by examples like the following, which show that verbs do not inflect for agreement in imperatives.

- (11) a. Somebody call(\*s) my wife!
- b. Don't (\*Doesn't) that boy over there move!
- c. You be (\*are) quiet now!

From the current theoretical perspective, however, it seems hard to sustain the postulation of syntactically inactive categories. It is neither consistent with the principle of Full Interpretation nor reconcilable with the concept of structural economy, which together dictate that functional heads are present in structural descriptions only if their presence is somehow motivated or contributes to interpretation at LF (Chomsky 1989; 1995: ch. 4). What is more, below I shall present a set of diachronic, cross-linguistic and morphosyntactic facts which are consistent with, or perhaps even suggest, the presence of (imperative)  $\phi$ -features in INFL (though these are evidently not associated with any agreement morphology).<sup>3</sup>

### 3.1 INFL(Agr)

First, whereas verbs are not overtly marked for agreement in imperative clauses nowadays, this was different in older stages of the English language. Into the Early Modern English period (c1450-1700), verbs had distinctive imperative forms, with no ending for the second person singular, as in (12b,d) (compare the non-imperative example in (12a), which shows *-(e)st*) and with a regular *-th* ending for the second person plural, as in (12c,e).<sup>4</sup>

- (12) a. *Wherfore criest thou?*  
why cry.2S.PRES.IND you.2S.NOM  
'Why do you cry?'
- b. *Boy, a boke anon thou bryng me!*  
boy a book immediately you.2S.NOM bring.2S.IMP me  
'Boy, you bring me a book immediately!'
- c. *Fy on yow! goyth hence Out of my presence*  
fie on you! go.2PL.IMP hence out of my presence  
'Fie on you! Now (you) get out of my sight.'
- d. *O goddesse immortal! Be helping now, [...].*  
o goddess immortal! be.2S.IMP helping now, [...]  
'O immortal goddess! (You) be helping now, [...].'
- e. *Bethe ware sirs.*  
be.2PL.IMP aware gentlemen  
'(You) be careful, gentlemen!'

Conceivably, then, the apparent absence of subject-verb agreement in imperative sentences is only apparent. It might simply be ascribed to the 'accidental' fact that English, whose morphology is well known to have impoverished over time as a whole, lost the imperative inflectional paradigm. This loss does not *necessarily* imply that imperatives also ceased to be specified for agreement on the more abstract level of features. Note that the ungrammatical variants of (11a-c) come as no surprise given that the *-s* inflection and the form *are* have always exclusively belonged to the paradigm of the present indicative (cf. the chapters on morphology in Hogg 1992- ). This is to say that one cannot expect to find them in imperative clauses in the first place, or draw any inferences from their absence. The minimal pairs in (11) only demonstrate that imperatives (no longer) show overt agreement marking, but they do not rule out the possibility that INFL is still associated with some (imperative)  $\phi$ -feature matrix. In other words, historical and present-day English imperatives might be regarded as differing with respect to the phonetic realisation of their (otherwise identical) INFL head only.

The hypothesis that imperatives in English have an INFL head carrying covert (imperative)  $\phi$ -features is also credible from a cross-linguistic point of view. There are languages which have retained relatively rich agreement

morphology and in imperatives use verb forms that are unique to the paradigm of the imperative (that is, they are distinct from any other verb form, for the same person, in the indicative, subjunctive, etc.). Platzack and Rosengren (1998) report that within Germanic, this is attested in at least German and Icelandic. (13) contains examples from German.<sup>5</sup>

- (13) a. *Du hilfst mir.*  
 you help.2S.PRES.IND me  
 ‘You help (are helping) me.’  
 b. *Hilf (du) mir!*  
 help.2S.IMP (you) me  
 ‘(You) help me!’  
 c. *Helft (ihr) ihm!*  
 help.2PL.IMP (you) him  
 ‘(You) help him!’

Above all, that subjects of imperatives appear to bear nominative Case is suggestive of their having an agreement specification (cf. also Beukema and Coopmans 1989). On the face of it, their Case seems difficult to determine. The limited range of subject DPs that can freely be used in English imperatives, such as the standard addressee pronoun *you*, all happen to be morphologically opaque.<sup>6</sup> Yet historically, the form of the second person pronoun varied not only for number but also for Case (viz. singular *thou* (NOM) / *thee* (ACC), and plural *ye* (NOM) / *you* (ACC)). Earlier imperative data, like (12b) above, exhibit unambiguously nominative forms. Likewise, Germanic languages which have kept a richer system of Case distinctions use nominative subjects in imperatives, as illustrated by the following example from Icelandic.<sup>7</sup>

- (14) *Kom thu / \*thig / \*ther / \*thin ekki!*  
 come.2S.IMP you.NOM you.ACC you.DAT you.GEN not  
 ‘Don’t you come!’

Furthermore, some English native speakers (A. Radford p.c.) allow for third person pronouns as subjects of imperatives, most favourably in conjunction structures or when accompanied by a modifying clause, and these must be nominative and cannot be, say, accusative. Examples are:

- (15) a. You stand by the door and *she / \*her* watch the window!  
 b. *He / \*Him* who carries the machine gun step away from the car!

The point is that nominative Case often seems to go hand-in-hand with agreement specification (as Chomsky already argued in 1981 and Schütze

1997 has shown more extensively). As for English, simple examples such as those in (16) show that an agreeing INFL (like an inflected auxiliary) takes a nominative subject, whereas the subject of a non-agreeing INFL (like the particle *to*) is accusative (or PRO).

- (16) a. She / \*Her [<sub>I</sub> is] watching the window.  
 b. I don't want [him / PRO / \*he [<sub>I</sub> to] carry a machine gun]

If the idea that subjects of present-day English imperatives have nominative Case is correct, then this would hint at (covert) specification for agreement features on the INFL head and the verb.

While the argument cannot be but indirect due to the poverty of the current English morphological system, I take the data in this section to provide sufficient justification for assuming that INFL carries covert imperative  $\phi$ -features (which historically were spelt out by imperative inflections).

### 3.2 The trigger for *do*-insertion in imperatives: INFL(Agr)

I turn now to the position of the auxiliary *do* at Spell-Out. The analyses according to which *do(n't)* in imperatives is inserted straight under C cannot easily be upheld in respect of Checking Theory. They assume at least one functional projection FP between CP and VP in the imperative clause structure, whose specifier is filled by the subject. I have identified the functional head F with INFL in the diagram below, which, as I just argued, presumably is specified for agreement. I take (imperative)  $\phi$ -features to be carried by the auxiliary when present, as it happens in finite declarative clauses.

- (17) Don't you try again!

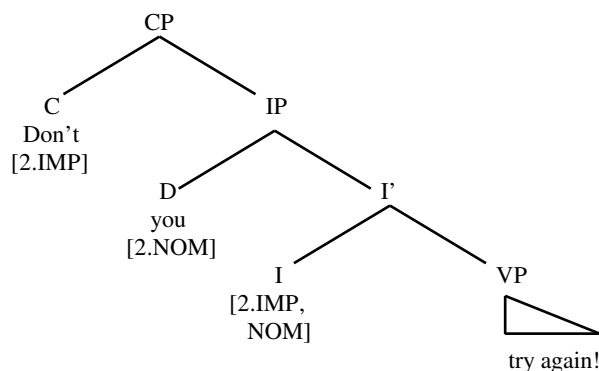

The problem is that if *do(n't)* is not at any stage of the derivation adjoined to INFL, it is unclear how non-interpretable  $\phi$ -features are checked with the

subject. Lowering the features of *do(n't)* by LF is, of course, not an option because of the c-command condition on Move. If one were to allow for feature raising from INFL to *do(n't)* in C, the question that arises is why in imperatives *do*-insertion would not target INFL for  $\phi$ -feature checking directly.

It seems improbable that *do(n't)* occurs in C at all in imperatives anyway. COMP has been regarded as a semantically meaningful category in being the locus of illocutionary force. This entails that the category is inherently specified for interpretable features such as Chomsky's (1995: ch. 4) feature *Q* for interrogatives (see also Rizzi 1997) which contribute to the sentence's interpretation and therefore are to survive to LF. Suppose that imperatives have an equivalent force-indicating feature in C (in the spirit of Katz and Postal 1964), call it *Imp*. Given the presumed interpretability of *Imp*, *do(n't)* would have to adjoin to C in the overt syntax just in case *Imp*, like *Q* in interrogatives, is accompanied by some strong verbal feature (or the trigger for *do(n't)* to raise to C, rather than being left adjoined to INFL where it checks its  $\phi$ -features, is missing, in conflict with Last Resort). By this reasoning, however, we would make the incorrect prediction that *do* should also be obligatory and occur before the subject in non-emphatic imperatives on a par with interrogatives (compare again (10a) and (10b) above). From the fact that *do(n't)* need not be resorted to in non-emphatic imperatives, it can only be concluded that the use of the auxiliary in other configurations is not induced by a strong feature. I therefore will not adopt the assumption that *do(n't)* is in C at Spell-Out.

Particulars of adverb placement appear to support this view empirically. Jackendoff (1972) noted that there is a certain class of English adverbs (including *merely*, *just* and *simply*) which cannot occur sentence-initially. In the structure of the finite declarative sentences below, they may be adjoined to I' and a projection of V, but adjoining them to IP is not possible.

- (18) a. She simply did not give them his address.  
           She [I' simply [I did] not give them his address]  
       b. She did not simply give them his address.  
           She did not [VP simply [V give] them his address]  
       c. \*Simply she did not give them his address.  
           Simply [IP she did not give them his address]

- (19) (\*Just) He (just) doesn't (just) believe what she says.

As the next examples demonstrate, sentence-initial positioning is an option in imperatives, however. If the highest adjunction-site of these adverbs is I', then *do(n't)* cannot occupy C but must be in the lower head INFL.

- (20) a. Do not simply give them your address!  
 Do not [<sub>VP</sub> simply [<sub>V</sub> give] them your address]!
- b. Simply do not give them your address!  
 [[<sub>IP</sub> [<sub>I</sub> Simply [<sub>I</sub> do] not give them your address]]!
- (21) (Just) don't anyone (just) believe what she says!<sup>8</sup>

So far, we may ask the question: how are the imperative facts to be interpreted, then? An analysis which has suggested itself all along is that in imperatives, *do* has the same syntax not as in interrogatives (or the obligatory absence of the auxiliary in non-emphatic constructions does not make sense) but as in finite declarative clauses (which is plausible since imperatives correspond to finite declaratives in all the relevant respects). Hence, *do* is inserted into INFL only where a negation or emphasis head intervenes between V and I so as to ensure that imperative  $\phi$ -feature checking with INFL can take place, but it is not forced to - and will therefore never - occur any higher than this in the imperative clause structure. The configuration I will henceforth be assuming for *do*-insertion in imperatives is as exemplified in (22) below (note that a possible covert CP-system has been left out for ease of exposition and that the position of the subject has deliberately been omitted here).

- (22) Do not try again!

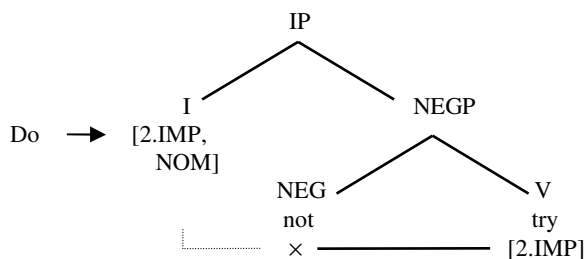

To recognise that with respect to the position of *do(n't)*, imperatives pattern with finite declarative clauses seems to be a step in the right direction, but it now becomes an interesting question as to why imperatives are nonetheless very much interrogative-like where the relative ordering of *do(n't)* and the subject is concerned. The pattern is shown in (23).

- (23) a. You didn't try again.      [<sub>IP</sub> You [<sub>I</sub> didn't] try again]  
 b. Didn't you try again?      [<sub>CP</sub> Didn't<sub>t</sub><sub>i</sub> [<sub>IP</sub> you <sub>t</sub><sub>i</sub> try again]]?  
 c. Don't you try again!      [<sub>IP</sub> [<sub>I</sub> Don't] you try again]!

Viewing things from the present perspective, it emerges that the inverted word order in imperatives arises by virtue of the absence of subject-raising to SpecIP. The impression that there has been subject-auxiliary inversion is therefore illusory and the parallelism with interrogatives clauses does not in fact exist. The following sections explore this hypothesis.

#### 4. The syntax of subjects in imperatives

##### 4.1 Against a SpecVP analysis

With the subject occupying a position below INFL, a possibility that immediately springs to mind is that in imperative *do(n't) Subject* strings, the subject follows the auxiliary because it is kept in situ in SpecVP, as indicated in (24) below.

(24) Don't you try again!

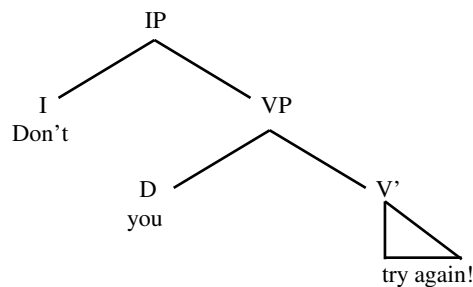

However, I agree with Potsdam (1998) that from all the relevant diagnostics it is evident that this cannot be the case (some of the examples below have been taken from his work). First, on the assumption that aspectual auxiliaries head a separate Aspect projection outside the theta-marking domain of VP (cf. e.g. Ouhalla 1991), the SpecVP analysis predicts that imperative subjects should appear to the right of them. The examples in (25) show that the opposite is true: they precede them.

- (25)
- a. \*Don't be [<sub>VP</sub> *anyone* waiting up for me all night]!
  - b. Don't *anyone* be [<sub>VP</sub> waiting up for me all night]!
  - c. \*DO have [<sub>VP</sub> *everyone of you* done your hair before we go]!
  - d. DO *everyone of you* have [<sub>VP</sub> done your hair before we go]!

Secondly, the subject does not elide in VP-ellipsis constructions, which suggests that it is VP-external at Spell-Out.

- (26) a. Rick walked out of the lecture, but don't everyone else \_\_\_\_,  
please!  
b. Bill didn't tell Mom what I did, so don't YOU \_\_ either!

In addition to this, example (27) demonstrates that it is possible to strand quantifiers in imperatives, which (after e.g. Sportiche 1988) can be taken as an indication that the subject has been moved out of the VP away from the quantifier.

- (27) Don't you ever both talk to me like that again!  
Don't you<sub>i</sub> ever [<sub>VP</sub> [both t<sub>i</sub>] [<sub>V'</sub> talk to me like that again]]!

Furthermore, imperatives can be passivised. If passive participles lack an external argument position, then passivisation must involve DP-movement from the canonical object position to a position outside the VP.

- (28) a. Everyone be checked over by a doctor!  
Everyone<sub>i</sub> be [<sub>VP</sub> [<sub>V</sub> checked over] t<sub>i</sub>] by a doctor!  
b. Don't you be fooled *t* by her behaviour!

A final piece of counter-evidence derives from the syntax of adverbs. A speaker-oriented adverb like *certainly* may precede but not follow a VP-adverb like *completely* in the following examples, which shows that *certainly* does not attach to VP (after Bowers' 1993 restrictive assumption that different adverb classes are licensed by separate heads).

- (29) a. Marianne has certainly completely solved the problem.  
Marianne has certainly [<sub>VP</sub> completely solved the problem]  
b. \*Marianne has completely certainly solved the problem.

As (30b) below shows, imperative subjects can appear to the left of adverbs like *certainly*, once again indicating that they are not in SpecVP.

- (30) a. Certainly everyone do at least the assigned problems!  
b. Everyone certainly [<sub>VP</sub> do at least the assigned problems]!

In sum, a SpecVP analysis of subject positioning in imperatives is inadequate.

#### 4.2 A SpecFP analysis

Accepting that 'inverted' imperative subjects do not occur in a VP-internal position, the logical possibility left to contemplate is that they are displaced no

further than the Spec position of some intermediate functional projection higher than VP but lower than IP in the structure of (31).

(31) Don't you try again!

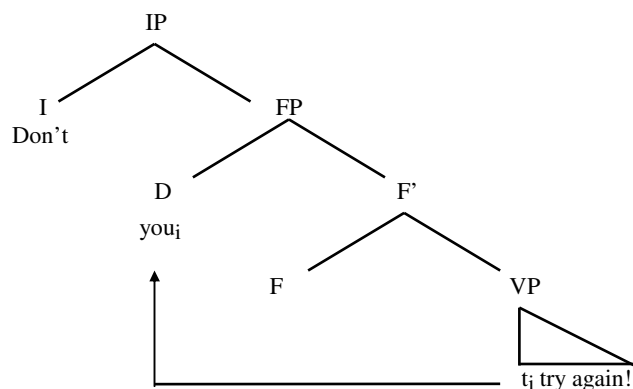

Scope facts in imperatives (from Schmerling 1982) have received little attention in the literature in the past, and yet they seem to provide evidence for the non-occurrence of movement into SpecIP. Consider the examples in (32) and (33), which illustrate a difference in scope between quantified subjects and negation in finite declaratives and imperatives.

(32) We all worked extremely hard over the past year, still  
*everyone didn't get a raise.*  
 a. = nobody got a raise *every > not*  
 b. = not everyone got a raise *not > every*

(33) I know all of you worked extremely hard over the past year, but  
*don't everyone expect a raise!*  
 a. ≠ nobody expect a raise! *\*every > not*  
 b. = not everyone should expect a raise *not > every*

Though scope judgements may be subject to some variation, most of my consultants agree that the finite declarative example (32) can in principle be assigned two different readings; one in which the quantifier (QP) *everyone* has scope over negation (paraphrased in (a)), and one where negation has scope over the QP (paraphrased in (b)) (for some speakers, necessarily with focal stress on *everyone*). Significantly, the reading on which the QP takes widest scope is strictly unavailable for the corresponding imperative sentence. That is, example (33) cannot be understood in the sense of (a).

It has long been standard to assume with May (1977; 1985) that for QPs to take scope over other elements in the sentence, they must raise and adjoin to some appropriate XP at LF. A sentence like *everyone didn't get a raise*, for

example, would then be assigned the LF structure given in (34), in which the QP has adjoined to IP.

(34) [IP [QP everyone]<sub>i</sub> [IP t<sub>i</sub> didn't get a raise]]

However, Hornstein (1995) argues that a separate rule of quantifier raising is no longer tenable in minimalism, and outlines a different approach to quantifier scope which aims to eliminate the rule from the grammar. He points out that if movement only occurs for the sake of checking morphosyntactic features, there is little reason for an element to move to an A'-position unless it must do so for feature checking, which is not obviously the case for quantified subjects. This said, Hornstein notes that quantified subjects are to undergo movement from SpecVP to SpecIP at any rate to check features with INFL, and that this operation automatically extends their scope domain. This way, operator scope can simply be a function of A-movement. In other words, A-movement, triggered by the requirements of checking theory, may simultaneously serve to expand a QP-subject's c-command domain, thereby enabling it to take scope over the remainder of the sentence. Accordingly, an appropriate LF representation of the example sentence would look like (35) instead.

(35) [IP [QP everyone]<sub>i</sub> [I didn't][VP t<sub>i</sub> get a raise]]

Combining this idea with the 'copy theory' of movement (Chomsky's 1993 minimalist analogue of reconstruction at LF), the *every* > *not* reading for the finite declarative sentence derives when at LF, the quantifier is interpreted in its surface position SpecIP, as in (36a). The *not* > *every* reading derives when, as in (36b), the copy of the quantifier in SpecVP is interpreted.

(36) a. [IP everyone didn't [VP ~~everyone~~ get a raise]]  
 b. [IP ~~everyone~~ didn't [VP t<sub>everyone</sub> get a raise]]

A CP analysis assumes a SpecIP position for imperative subjects, with subsequent auxiliary inversion from I to C. Note that this analysis predicts quite wrongly that negative imperatives also are ambiguous. In the higher C position negation should always have scope over the QP, whilst the QP could take scope over negation from SpecIP if the latter were 'LF-reconstructed'. Compare (37a) and (37b):

(37) a. [CP don't [IP everyone t<sub>don't</sub> [VP t<sub>everyone</sub> expect a raise]]]  
 b. [CP ~~don't~~ [IP everyone t<sub>don't</sub> [VP ~~everyone~~ expect a raise]]]

Crucially, for the *every > not* reading to become available, negation must fall within the scope domain of the quantifier. In finite declarative clauses, a quantified subject c-commands, hence bears scope over, everything contained within I' from its derived position in SpecIP, which includes *do(n't)* under INFL. The reading being absent from 'inverted' imperatives implies that while there may be movement to an intermediate Spec position, subjects are not moved as far as the Spec position of IP. In this case it makes no difference whether the higher or the lower link of the chain is interpreted in (38). The QP will always be in the scope of negation.

- (38) a. [IP don't [FP everyone [F F][VP t<sub>everyone</sub> expect a raise]]]  
 b. [IP don't [FP ~~everyone~~ [F F][VP t<sub>everyone</sub> expect a raise]]]

The analysis of 'inverted' imperatives pursued here is in its essentials similar to the derivation of expletive-associate constructions of the type illustrated in (39) below (cf. e.g. Felser and Rupp, to appear). In these constructions, the associate/thematic subject (*many students*) similarly fails to occur in SpecIP, which is filled by the expletive (*there*). As expected under the FP analysis, 'inverted' imperatives and existential sentences behave alike with respect to scope restrictions on their QP-subjects.

- (39) There aren't many students waiting outside.  
 a. ≠ many students are not waiting outside \**every > not*  
 b. = not many students are waiting outside *not > every*

E. Potsdam (p.c.) has pointed out to me that the argument becomes unpersuasive once interrogatives are taken into consideration. As indicated in (40a,b) below, on the above assumptions these should be ambiguous between a narrow and a wide scope reading for quantified subjects.

- (40) *Didn't everyone get a raise?*  
 a. [CP ~~didn't~~ [IP everyone t<sub>didn't</sub> [VP t<sub>everyone</sub> get a raise]]]?  
*every > not* ('Did nobody get a raise?')  
 b. [CP didn't [IP everyone t<sub>didn't</sub> [VP t<sub>everyone</sub> get a raise]]]?  
*not > every* ('Did not everyone get a raise?')

In actual fact, the narrow scope reading given in (b) is the *only* possible reading of (40). This seemingly removes the ground for claiming that the absence of wide quantifier scope in 'inverted' imperatives reveals that the CP analysis is incorrect. However, I suspect that the possibility of forming negative interrogative clauses with *not* may play some role here. As in the case of (40), the derivation of (41) is predicted to result in scope ambiguity.

Similarly but conversely, the example can only be understood with the wide scope reading for the QP in (a).

- (41) *Did everyone not get a raise?*
- a. [CP did [IP everyone t<sub>did</sub> [NEGP not [VP t<sub>everyone</sub> get a raise]]]]?  
*every > not* ('Did nobody get a raise?')
  - b. [CP did [IP ~~everyone~~ t<sub>did</sub> [NEGP not [VP t<sub>everyone</sub> get a raise]]]]?  
*not > every* ('Did not everyone get a raise?')

That the QP and negation apparently are interpreted in their surface position in (40) and (41) could be related to the fact that in interrogatives, the respective negative elements (*Auxn't* and *not*) occur in different structural positions at Spell-Out (above, hence taking scope over, and below, hence in the scope of, the subject in SpecIP). If the two interpretations are made available by the syntax, LF-reconstruction is arguably unmotivated. Wide quantifier scope cannot be yielded in 'inverted' imperatives in a similar way because contrary to interrogatives, they cannot be negated with *not*. This contrast is not straightforward under an interrogative-type CP analysis, but will be shown to fit the FP approach.

Potsdam (this volume) objects that this account necessarily gives up on the idea that all of the scope facts can be covered by a uniform explanation. I am not sure that it does: reconstruction in negative interrogatives for scope purposes is only thought to lack motivation. Potsdam argues that with *don't*-interrogatives and *don't*-imperatives showing the same scope pattern, they must have identical CP-structures.<sup>9</sup> Though his contribution does not focus on quantified subjects, I understand that he would explain the scope contrast between ambiguous finite declaratives and non-ambiguous interrogatives/imperatives by assuming that unlike raised QPs, I-to-C moved negation cannot reconstruct. Consequently, the scope of *don't* in interrogatives/imperatives is fixed by its surface position in C. Such an account still allows for non-uniformity.

An issue that I will leave to be settled is the identity of FP. The existence of a functional layer between V and I in English clause structure (different from the object-oriented AGRoP-type) has been argued for on independent grounds, and is identified with the projection of an ASP(ect) head in Tenny (1987) and Ouhalla (1991). While in the remainder of this contribution I will stick to the neutral label FP, AspP would seem a suitable candidate. First, it is consistent with the absence of wide scope for quantified subjects in 'inverted' imperatives. In order for the data to fall out, *don't* should at no stage in the derivation be in the scope of the QP in SpecFP. As far as I know, the auxiliary *do* has not been associated with aspectual features, in which case *do*-insertion need only apply to the higher INFL head for the checking of imperative  $\phi$ -

features. Second, in overtly aspectual imperative constructions, like (25b,d), the subject shows up between *do(n't)* and the aspectual auxiliary. Thirdly, the possibility of an AspP receives some semantic motivation from interesting work by Flagg (2001) on differences between overt subject imperatives and covert subject imperatives at the syntax-semantics interface. One of the observations Flagg makes is that there is a restriction against overt subjects with certain predicates, exemplified by (42) versus (43).

- (42) a. Keep doing your homework!  
b. You keep doing your homework!

- (43) a. Love your doggy!  
b. \*You love your doggy!

She characterises the contrast as one between stage-level predicates and individual-level predicates. Flagg goes on to note that the felicity conditions for the examples in (42) differ. In a situation in which a child is sitting at the kitchen table doing homework when the doorbell rings, a parent can say (42a) as a word of encouragement if the child shows no sign of stopping as the parent goes to the door. (42b), on the other hand, is odd for this situation. But if the child stops doing the homework, or even shows signs of being about to stop, (42b) becomes appropriate. Flagg argues that the felicity of using an overt subject depends in part on whether the event being ordered has a specific starting-point. She suggests that in such contexts, the subject might stay low because it is to be licensed by an aspectual feature [+start].

## 5. Subject positioning revisited

It is common knowledge that English has a rigid word order in respect of the surface position for subjects. So far, I have concentrated on 'inverted' imperative constructions, arguing that subjects in imperatives have an exceptional distribution in that they may not be placed in SpecIP. On closer inspection, it appears that their syntax is even more unusual and the data more complicated. As previously noted by Davies (1986), imperatives can be expressed with inverted *do(n't) Subject* strings as well as with non-inverted *Subject do(n't)* sequences. Under the FP analysis, the source of this word order variation must lie in variation in the position of the subject. While the subject can occur in some intermediate A-position, apparently it may undergo subsequent movement to a higher Spec position at the left-hand side of the structure, very much like SpecIP in fact. Consider the negative examples in (44) and (45) (inspired by Davies 1986):

- (44) a. *Don't you go to the party!*  
 [IP [I Don't]<sub>i</sub> [FP you<sub>i</sub> [F F] [VP t<sub>i</sub> [V go] to the party]]]!
- b. *Don't anyone with a mobile phone use it during the flight!*
- c. (I remember John being very upset last year, so please)  
*don't both of you forget his birthday this time!*
- (45) a. OK, *you don't go to the party, then!*  
 (If that's what you want.)  
 .[IP You<sub>i</sub> [I don't]<sub>i</sub> [FP t'<sub>i</sub> [F F] [VP t<sub>i</sub> [V go] to the party]]]!
- b. *Anyone with a mobile phone don't use it during the flight!*
- c. *Both of you don't forget John's birthday this time!*<sup>10</sup>

Subject position likewise varies in emphatic imperatives. For illustration, compare the inverted orders in (46) to the non-inverted orders in (47):

- (46) a. (Bill, I am begging you,) *DO YOU* support him!  
 [IP [I DO]<sub>i</sub> [FP YOU<sub>i</sub> [F F] [VP t<sub>i</sub> [V support] him]]]!
- b. *DO SOMEone* open the door!
- c. *DO EVERYbody* give it a try!
- (47) a. *You DO* support him! (Or I'll never speak to you again.)  
 [IP You<sub>i</sub> [I DO]<sub>i</sub> [FP t'<sub>i</sub> [F F] [VP t<sub>i</sub> [V support] him]]]!
- b. *Someone DO* open the door!
- c. *Everybody DO* give it a try!

Interestingly, it turns out that such variability is not merely an idiosyncrasy of standard English imperatives, but also characterises imperatives in some other English varieties and Germanic languages. The data in (48) below are from a Belfast English variety studied by Henry (1995). She argues that on the assumption that the position of adverbs is fixed, the alternative orderings of *you* and *carefully* must arise from the subject distributing quite freely.

- (48) a. Write *carefully you* that letter!  
 b. Write *you carefully* that letter!

(49) is an example from Swedish where, according to Platzack and Rosengren (1998), imperative subjects can surface in a range of different positions.

- (49) *Spring (DU) alltså (DU) hem (DU) meddetsamma (DU)!*  
 run (you) thus (you) home (you) immediately (you)  
 ‘Thus, you run home immediately!’

Thus, flexibility in the distribution of subjects would appear to be a more general feature of imperatives across Germanic languages.

## 6. Marking negation: the limits of *not*

Finally, I would like to show that the FP analysis I am proposing seems to go some way towards explaining the (non-)availability of *not*. Some data are given in (50-51) below (adapted from Postdam 1998).

I know I’ve done wrong but I can’t survive on my own. Oh please,

- (50) a. *Don’t you / anyone* desert me!  
 b. *Those with a heart don’t* desert me!  
 c. *Don’t* desert me!
- (51) a. \**Do you / somebody not* desert me!  
 b. \**Do not you / anyone* desert me!  
 c. *Do not ALL of you* desert me!  
 d. *One of you do not* desert me!  
 e. *Do not* desert me!

These examples show that while (1) all types of imperative construction can freely be negated by means of *don’t* (cf. (50a-c)), (2) negating ‘inverted’ imperatives with *not*, which is comparatively rare anyway, yields acceptable results only in certain contexts (compare (51a,b) to (51c)), whereas (3) structures in which the subject occurs sentence-initially or is covert are not restricted in this way.

The FP analysis assumes that imperative *do not* constructions have the following basic structure:

- (52) [IP (Subj<sub>i</sub>) [I do][NEGP [NEG not][FP (Subj<sub>j</sub>) F [VP t<sub>i</sub> V ...]]]]

As a beginning, the non-occurrence of *do Subject not* sequences (which poses an immediate problem for the CP analysis) is not unexpected. As a matter of fact, it follows directly from the proposed configuration for the trivial reason that a sentence like (51a) cannot be assigned a legitimate structural

description. There is no suitable (A-)slot between IP and the FP for the subject to be moved into, as indicated below.<sup>11</sup>

(53) \*Do you not desert me!

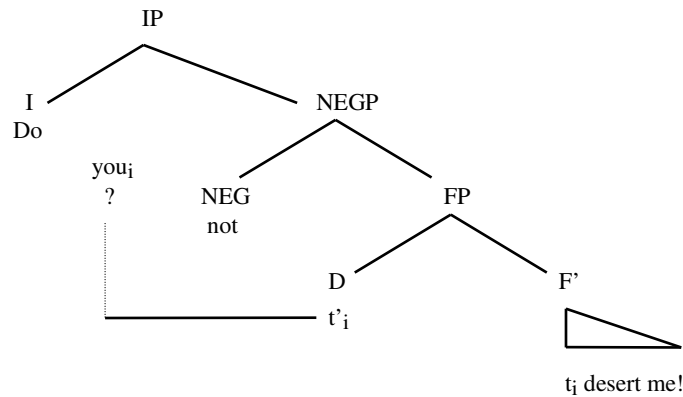

The really pertinent question is why *do not Subject* strings are only marginally possible when the subject occurs in the Spec position of FP (cf. (51b) versus (51c)). Following Chomsky (1995: ch. 4), I assume that where the subject is raised no further than SpecFP (as in 'inverted' constructions), the checking of, for example, nominative Case must be achieved by adjoining the subject's features to INFL(*do*) by LF. The chain yielded by this procedure does not fit the 'traditional' notion of A-chain in any straightforward way as it involves (feature) raising from an A-position to a head node. It may be, then, that the ill-formedness of (51b) and many similar examples derives from the same locality condition that disallows movement to a head skipping another head in the case of verbs. I take it that head-adjunction cannot succeed across an intermediate syntactic head, and suggest that structures like (54) are ruled out because *not* breaks the necessary adjacency between IP and the FP.

(54) \*Do not you desert me!

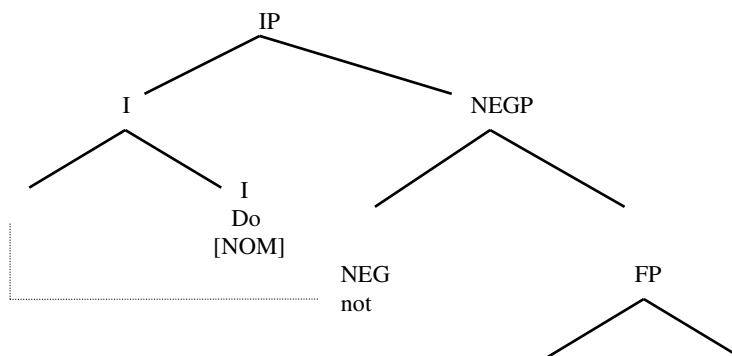

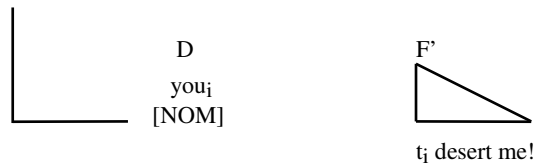

Consider now (51c) (repeated in (55) below) and notice that the most natural reading of the example is not (a), but (b), which concerns constituent negation.

- (55) I know I've done wrong but I can't survive on my own.  
 Oh please, do not ALL of you desert me!  
 a. I request that all of you not desert me  
 b. I request that not all of you desert me

In this function, *not* has a crucially different distribution: in the structure of (55), it adjoins to the QP, as shown in (56).

- (56) Oh please, do not ALL of you desert me!

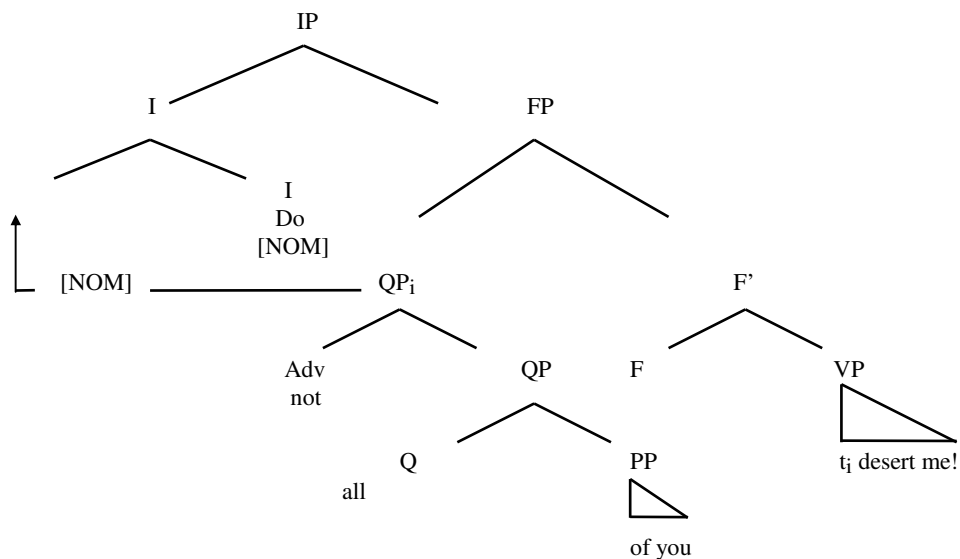

Here, *not* does not interfere with the head-adjunction procedure because constituent *not* is not a syntactic NEG head. What seems to be crucial for *do not Subject* constructions to be felt acceptable, then, is whether or not *not* can receive a constituent negation interpretation. The acceptability of these constructions declines according to how readily such a reading is available. Where an appropriate context is difficult to construe, as in the case of (54), *do not Subject* strings are judged to be bad.

Clausal *not* may, on the other hand, be used in structures with a sentence-initial overt subject or a covert subject. This contrast is accommodated in a

system in which pre-*do* and post-*do* subjects are not only distinguished with respect to their distribution, but also have different checking mechanisms. As with finite declarative subjects, *one of you* in (57) A-moves into SpecIP, where it can enter into an ‘ordinary’ Spec-head agreement relation with INFL(*do*). Where checking happens in this manner, the presence of *not* does not affect the derivation.<sup>12</sup>

(57) One of you do not desert me!

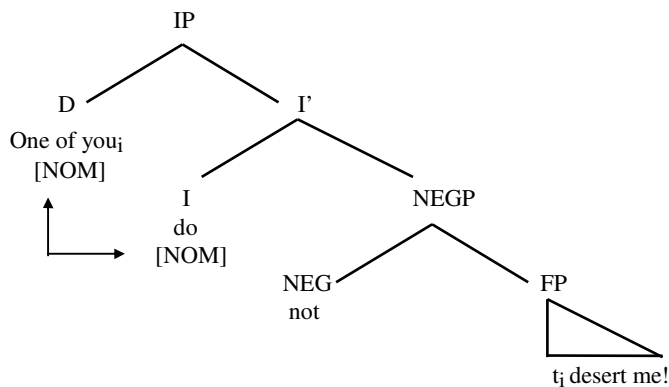

The fact that negative ‘inverted’ constructions with *don’t* are not restricted implies that in the syntactic representation of (58), *don’t* in INFL and the subject in SpecFP are adjacent. This in turn suggests that the bound morpheme *n’t* is not an independent NEG head, but that *Auxn’t* forms rather are unitary elements in the lexicon, which get generated under INFL directly.<sup>13,14,15</sup>

(58) Don’t you desert me!

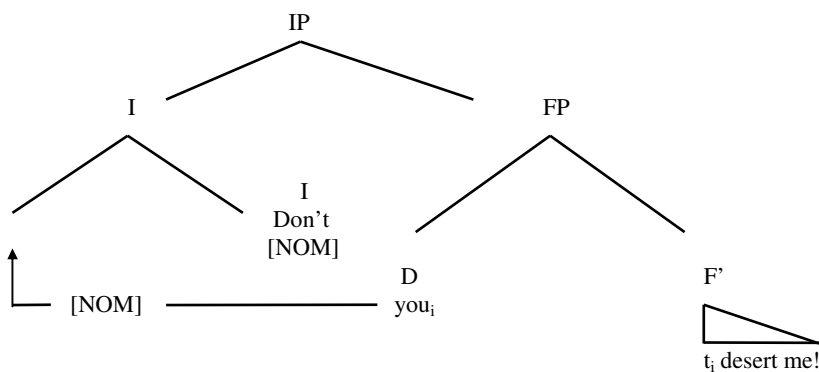

Expletive-associate constructions may again serve for comparison. Similar to what I assume for ‘inverted’ imperative subjects, it has been proposed that the features of the low thematic subject are checked when they adjoin to INFL. Hence, existential sentences should equally be sensitive to the *Auxn’t* / *not* distinction (in addition to the absence of wide quantifier scope that they share with ‘inverted’ imperatives). This expectation is borne out (A. Radford p.c.):

- (59) a. \*There is not anyone waiting outside.<sup>16</sup>  
 [IP There [I is][NEGP [NEG not] anyone waiting outside]]  
 b. There isn't anyone waiting outside.  
 [IP There [I isn't] anyone waiting outside]

## 7. Conclusions

It appears that many of the problems traditionally associated with imperatives have arisen from (potentially misleading) *do(n't) Subj* sequences occurring. This gives the impression that imperatives are derivationally similar to interrogatives and makes their quite different behaviour look odd. I have proposed an alternative analysis which treats the syntax of *do(n't)* in imperatives in a fashion maximally analogous to finite declarative clauses, and argues that there are more advantages to analysing the inverted order as a reflex of the scope of subject raising. Such an approach becomes feasible in a framework which admits several functional projections (cf. e.g. Ouhalla 1991), like AspP, whose specifiers may each serve as a potential A-position. The proposed account was shown to allow for an explanation of the particulars of quantifier scope and *not* in 'inverted' imperatives, in which they pattern similarly with 'low subject' expletive-associate constructions.

The FP analysis raises the following issues for future research:

1. What is the precise nature of the different surface positions for subjects in imperatives?
2. To what extent do subjects distribute freely over these positions, or is their distribution conditioned in any way? When do they occur in which designated position and why?
3. Is the distribution of subjects flexible in Germanic imperatives cross-linguistically? If not, why not? (see Bennis, this volume, who shows that the possibilities for subjects in imperatives in Dutch are much more restricted than in English.)

The variation found in the syntax of imperative subjects in English challenges the narrow position in Chomsky (1995: ch. 4) that an element's distribution is strictly determined by its morphosyntactic properties, and it exposes the limits of the mechanism of feature strength. Morphosyntactic features are assigned every time a certain syntactic structure is created, and should they force movement to occur then displacement must be obligatory. In this sense, all cases of apparently optional movement are problematic. The otherwise rigid SpecIP positioning of subjects in English has been formalised by assigning INFL an EPP-feature. As I understand it, the EPP only imposes that sentences have a subject, however. In its original formulation, it has rather

little (if anything) to say about the actual position of the subject in the structure, but it has very much come to be used as a movement-triggering tool. One could resort to saying that depending on whether the imperative subject occurs in SpecIP or SpecFP, an EPP-feature is optionally present in INFL or F. Needless to say, such a statement of the facts is theoretically unsatisfactory because of its descriptive nature and lack of explanatory qualities.

In recent years, there has been a proliferation of studies arguing for relations between syntactic positions and semantic interpretations or discourse functions/prosody (Diesing 1992, de Hoop 1992, Barbiers 1995, Reinhart 1995, Rizzi 1997 and others). This line of research is proving very fruitful, and in effect promoted by the very minimalist working hypothesis that any imperfections in an optimal syntax (such as displacement) are ultimately due to properties of the PF and LF interfaces. Interface-related approaches seem to have a better prospect of explaining optional movement in principled terms as intended readings or discourse roles may vary from context to context.

It will be worthwhile to inquire into the distribution of subjects in imperatives from this perspective. It may not be a coincidence that languages in which the subject can be dropped more generally are also known for the distribution of subjects being quite variable, and to be interrelated with semantic/discourse/prosodic notions (Zubizarreta 1995, Grimshaw and Samek-Lodovici 1998, Pinto 1997, Costa 1998, among others). Further study of the data is needed to establish whether there are such correlations in imperatives. For some findings to this effect, I refer the reader to Davies (1986), Platzack and Rosengren (1998), Flagg (2001) and Rupp, forthcoming.

## Notes

\* This contribution is based on the author's Ph.D. dissertation (1999). I especially thank A. Radford for constructive comments and useful suggestions.

1. In view of the controversy about AGR(ement) phrases as first postulated by Pollock (1989) in his 'split-INFL' framework, I will assume a basic phrase marker with no AGRPs and use the label IP informally to refer to the highest 'inflectional' projection present. (See Iatridou 1990 and, more recently, Chomsky 1995: ch. 4 for discussion.)

2. In Pollock (1989) and Platzack and Rosengren (1998), *don't* is an idiosyncratic imperative verb. As will become clear directly, I see no need to assume such an exceptional element.

3. In the literature on imperatives, opinions are somewhat divided as to whether or not imperative clauses have tense specification. For a variety of different views, see, amongst others, Culicover (1971; 1976), Stockwell et al.

(1973), Ukaji (1978), Akmajian et al. (1979), Lasnik (1981; 1994), Davies (1986), Pollock (1989), Beukema and Coopmans (1989), Zhang (1990), Zanuttini (1991), Henry (1995) and Platzack and Rosengren (1998). Since this matter does not affect the essence of the argument, I shall leave it open. For present purposes, it suffices to show that imperatives are specified for agreement (at least).

4. The examples in (12) have been taken from Visser (1963-1973), who cites the following sources for (a-e), respectively: (a) c1479 Earl Rivers, *The Cordyal* (ed. Mulders) 92, 22 (p. 1550); (b) c1450 *Cov. Myst.*, Mary Magd. (Pollard) 1181 (p. 18); (c) 1460 *Towneley Myst.* ii, 204 (p.16); (d) c1402 *Lydgate, Complaint of the Black Knight* (ed. Krauser) 90, 628 (p. 1960); (e) 1480 *Caxton, Chron. Eng.* cxcvii, 175 (p. 16).

5. This is also true of many members of the Romance (e.g. Italian, Spanish) and Balkan (e.g. Greek, Rumanian, Albanian) families, cf. Zanuttini (1991; 1994; 1997), Rivero (1994a; 1994b) and Rivero and Terzi (1995). I refer to these studies for a description and analysis of some of the interesting properties of imperatives in such languages.

6. Broadly speaking, the condition seems to be that subject DPs must lend themselves to an addressee interpretation (Bolinger 1967, Downing 1969, Stockwell et al. 1973, Ukaji 1978, Schmerling 1982, Davies 1986, Zhang 1990, Platzack and Rosengren 1998, and many others). Expressions that can be construed in this way include quantifiers, demonstratives, partitives, bare noun plurals and certain definite phrases, whereas first and third person pronouns and indefinites are normally out.

- (i) a. *Everybody* listen to me!  
b. *Those in the front row* stop giggling!  
c. *The whole lot of you* get out of here at once!  
d. (New) *students* (among you) sign up at the front door!  
e. *The boy in the corner* stand up!
- (ii) a. \**We* / \**I* take a look at this!  
b. \**He* / \**They* / \**A man* come here!

Potsdam (1998) offers more detailed discussion and some qualifying observations.

7. Again, this is the same in the Romance and Balkan languages mentioned in note 5.

8. The relevance of the syntax of these adverbs for the analysis of imperatives was recognised by Potsdam (1998). In this volume, Potsdam cites anomalous

examples with *Adv-don't-Subject* order as evidence against the present account and in favour of his CP-analysis of inverted constructions. However, (21) above demonstrates that the order is not in fact strictly ill-formed. I suspect that non-syntactic factors may bear on the acceptability of such data. These need to be considered more carefully.

9. Potsdam backs up his argument by showing that other I-to-C structures are similarly unambiguous. (i) involves Negative Preposing. Note that with *not*, the scope relation is again reversed.

- (i) Only on Fridays doesn't everybody come. (*not > every* only)
- (i') Only on Fridays does everybody not come. (*every > not* only)

Note also that some CP constituents, like inverted conditionals, do seem to show scope ambiguity in fact (M. Jones p.c.):

- (ii) a. Hadn't everyone got a raise, they would all have gone on strike.  
*every > not* ('If everyone hadn't got a raise, ...')
- b. Hadn't everyone got a raise, some employees would have felt undervalued.  
*not > every* ('If not everyone had got a raise, ...')

Potsdam further argues that his CP analysis is superior to the FP analysis with respect to scope interactions between negation and quantified objects or adjuncts. On his assumptions, the CP analysis can - but the FP analysis cannot - capture the observation that interrogatives and 'inverted' imperatives only have a *NEG > QP* reading, whereas finite declaratives in addition can be construed with *QP > NEG*. One of the examples that he cites for illustration is from Moon (1999).

- (iii) . He didn't play football for many years.  
= He played football for not many years *not > many*  
= For many years, he did not play football *many > not*
- (iv) Don't you play football for many years!  
= You should play football for not many years  
*not > many*  
≠ You should wait many years before playing football  
*\*many > not*

However, sometimes creating an appropriate context can make a reading available, as in:

- (v) Concerned coach to player: Your injury is very serious. I am

warning you. You have to be careful or it will only get worse. So,  
*Don't you play football for many years!* (Then we'll see.)

Further, my consultants did not fully agree with the way Potsdam judges some the examples, and in particular found the interrogatives to be ambiguous. Since these judgements are not my own, I refer the reader to his contribution in this volume.

10. One could be inclined to think (with Thorne 1966) that these sentence-initial DPs really are vocatives. However (as argued extensively by Potsdam 1998), while DPs may, of course, be used as vocatives in imperatives, and vocatives and imperative subjects seem to have a very similar function of identifying the addressee(s), there are good reasons for making a distinction. Notice, for example, (1) that vocatives must be pronounced with an intonation break, orthographically indicated by a comma (cf. (ia,b)), while DPs in imperatives need not be (cf. (45c) above); (2) that there are DPs which may serve as the subject of an imperative but cannot occur as vocatives (the classic example being *nobody*, cf. the contrast between (iia) and (iib)); and (3) that (as the examples in (iii) show) in imperatives some grammatically third person DPs are able to bind both third and second anaphors, whereas the binding potential of vocatives is restricted to second person.

- (i) a. Both of you, John's birthday is tomorrow.  
b. \*Both of you John's birthday is tomorrow.
- (ii) a. Nobody move!  
b. \*Nobody, move!
- (iii) a. [Passengers with luggage]<sub>i</sub> don't leave their<sub>i</sub> / your<sub>i</sub> valuables unattended!  
b. [Ladies and gentlemen]<sub>i</sub>, please look after \*their<sub>i</sub> / your<sub>i</sub> personal belongings!

11. As Potsdam (1998) points out, well-formed examples like (i) do not involve clausal negation but constituent negation.

- (i) DO AT LEAST SOME of you not snub our guest!  
[<sub>IP</sub> [<sub>I</sub> Do][<sub>FP</sub> [AT LEAST SOME of you]<sub>i</sub> [<sub>F</sub> F][<sub>VP</sub> not  
[<sub>VP</sub> t<sub>i</sub> [<sub>V</sub> snub] our guest]]]]!

12. Since *pro* occurs in nominative positions in typical *pro*-drop languages, I assume that the covert imperative subject is *pro*, and that *pro* is in SpecIP in grammatical *do not* constructions such as *Do not desert me!* I refer to Zhang

(1990), Henry (1995) and Potsdam (1998) for views on how *pro* might be licensed in imperatives in an otherwise non-*pro*-drop language like English.

13. This account is, in a sense, reminiscent of the solution proposed by Beukema and Coopmans (1989) within a GB-model.

14. Conform the minimalist assumption that words are drawn from the lexicon fully inflected. See Zwicky and Pullum (1983) for convincing arguments that *n't* is an affix, not a clitic.

15. On this account, I have to assume that the phrase marker of *don't* constructions does not include a NEGP, or else it should have some blocking impact. While this assumption may not be problematic in relation to Checking Theory (as any negative features carried by *don't* are arguably interpretable, exempted from checking), it is true that it leads to different LF-representations for synonymous examples like (ia) and (ib), which is inconsistent with the idea that semantically equivalent expressions have the same structure at LF. I will have to leave this matter unresolved.

- (i) a. Do not desert me!  
[IP *pro* [I do][NEGP [NEG not] desert me]]!
- b. Don't desert me!  
[IP *pro* [I don't] desert me]!

16. As in examples like (56), *not* in (i) below presumably expresses adjoined constituent negation.

- (i) There are not many students waiting outside.  
[IP There [I are][VP [not many students] waiting outside]]

## References

- Akmajian, A., Steele, S. and Wasow, T. 1979. "The category AUX in universal grammar". *Linguistic Inquiry* 10: 1-64.
- Barbiers, S. 1995. The syntax of interpretation. Ph.D. dissertation, HIL/ Universiteit Leiden.
- Beukema, F. and Coopmans, P. 1989. "A government-binding perspective on the imperative in English". *Journal of Linguistics* 25: 417-436.
- Bolinger, D. 1967. "The imperative in English". In *To Honor Roman Jakobson: Essays on the Occasion of his Seventieth Birthday*, M. Halle, H.

- Lunt, H. McClean and C. van Schooneveld (eds), 335-362. The Hague: Mouton.
- Bowers, J. 1993. "The syntax of predication". *Linguistic Inquiry* 24: 591-656.
- Chomsky, N. 1981. *Lectures on Government and Binding*. Dordrecht: Foris.
- Chomsky, N. 1989. "Some notes on economy of derivation and representation". In *Functional Heads and Clause Structure* [MIT Working Papers in Linguistics 10], I. Laka and A. Mahajan (eds), 1-32. Cambridge, Mass.: MIT Press.
- Chomsky, N. 1993. "A minimalist program for linguistic theory". In *The View from Building 20: Essays in Linguistics in Honor of Sylvain Bromberger*, K. Hale and S.J. Keyser (eds), 1-52. Cambridge, Mass.: MIT Press.
- Chomsky, N. 1995. *The Minimalist Program*. Cambridge, Mass.: MIT Press.
- Cohen, A.-V. 1976. "Don't you dare!". In *Harvard Studies in Syntax and Semantics* 2, J. Hankamer and J. Aissen (eds), 174-196. Cambridge, Mass.: Harvard University.
- Costa, J. 1998. Word order variation: A constraint-based approach. Ph.D. dissertation, HIL/Universiteit Leiden.
- Culicover, P. 1971. Syntactic and semantic investigations. Ph.D. dissertation, MIT.
- Culicover, P. 1976. *Syntax*. New York: Academic Press.
- Davies, E. 1986. *The English Imperative*. London: Croom Helm.
- Diesing, M. 1992. *Indefinites*. Cambridge, Mass., MIT Press.
- Downing, B. 1969. "Vocatives and third-person imperatives in English". *Papers in Linguistics* 1: 570-592.
- Felser, C. and Rupp, L. to appear. "Expletives as arguments: Evidence from existential sentences in Germanic". *Linguistische Berichte*.
- Flagg, E. 2001. "You can't say that: Restrictions on overt subjects in the English imperative". Paper presented at the annual conference of the *Chicago Linguistics Society*.
- Grimshaw, J. and Samek-Lodovici, V. 1998. "Optimal subjects". In *Is The Best Good Enough: Optimality and Competition in Syntax*, P. Barbosa, D. Fox, P. Hagstrom, M. McGinnis and D. Pesetsky (eds.), 193-219. Cambridge, Mass.: MIT Press.
- Han, C.-H. 2000. *The Structure and Interpretation of Imperatives: Mood and Force in Universal Grammar*. New York: Garland.
- Henry, A. 1995. *Belfast English and Standard English: Dialect Variation and Parameter Setting*. Oxford: Oxford University Press.
- Hogg, R. (general ed.). 1992-. *The Cambridge History of the English Language*. Cambridge: Cambridge University Press.
- de Hoop, H. 1992. Case configuration and noun phrase interpretation. Ph.D. dissertation, Universiteit Groningen.
- Hornstein, N. 1995. *Logical Form: From GB to Minimalism*. Oxford: Blackwell.

- Iatridou, S. 1990. "About Agr(P)". *Linguistic Inquiry* 21: 551-577.
- Jackendoff, R. 1972. *Semantic Interpretation in Generative Grammar*. Cambridge, Mass.: MIT Press.
- Katz, J. and Postal, P. 1964. *An Integrated Theory of Linguistic Descriptions*. Cambridge, Mass.: MIT Press.
- Laka, I. 1990. Negation in syntax: on the nature of functional categories and projections. Ph.D. dissertation, MIT.
- Lasnik, H. 1981. "Restricting the theory of transformations: A case study". In *Explanations in Linguistics: The Logical Problem of Language Acquisition*, N. Hornstein and D. Lightfoot (eds), 152-173. London: Longman.
- Lasnik, H. 1994. Verbal morphology: *Syntactic Structures* meets the Minimalist Program. Ms., University of Connecticut.
- May, R. 1977. The grammar of quantification. Ph.D. dissertation, MIT.
- May, R. 1985. *Logical Form: Its Structure and Derivation*. Cambridge, Mass.: MIT Press.
- Moon, G. (1999). "Don't imperatives". *Harvard Working Papers in Linguistics* 7: 93-107.
- Ouhalla, J. 1991. *Functional Categories and Parametric Variation*. London: Routledge.
- Pinto, M. 1997. Licensing and interpretation of inverted subjects in Italian. Ph.D. dissertation, Universiteit Utrecht.
- Platzack, C. and Rosengren, I. 1998. "On the subject of imperatives: A minimalist account of the imperative clause". *The Journal of Comparative Germanic Linguistics* 1: 177-224.
- Pollock, J.-Y. 1989. "Verb movement, universal grammar and the structure of IP". *Linguistic Inquiry* 20: 365-424.
- Potsdam, E. 1998. *Syntactic Issues in the English Imperative*. New York: Garland.
- Reinhart, T. 1995. Interface strategies. *OTS Working Papers in Linguistics*, OTS/Utrecht University.
- Rivero, M.-L. 1994a. "Negation, imperatives and Wackernagel effects". *Rivista di Linguistica* 6: 91-118.
- Rivero, M.-L. 1994b. "Clause structure and V-movement in the languages of the Balkans". *Natural Language and Linguistic Theory* 2: 63-120.
- Rivero, M.-L. and Terzi, A. 1995. "Imperatives, V-movement and logical mood". *Journal of Linguistics* 31: 301-332.
- Rizzi, L. 1997. "The fine structure of the left periphery". In *Elements of Grammar: Handbook in Generative Syntax*, L. Haegeman (ed.), 281-337. Dordrecht: Kluwer.
- Rupp, L. 1999. Aspects of the syntax of English imperatives. Ph.D. dissertation, University of Essex.
- Rupp, L. forthcoming. "Why (not) move? The view from imperatives". In *Proceedings of the Motivating Movement Conference*. Oxford: Oxford University Press.

- Schmerling, S. 1982. "How imperatives are special, and how they aren't". In *Papers from the Parasession on Nondeclaratives*, R. Schneider, K. Tuite, and R. Chametzky (eds), 202-218. The Chicago Linguistics Society, University of Chicago.
- Schütze, C. 1997. INFL in child and adult language: Agreement, case and licensing. Ph.D. dissertation, MIT.
- Sportiche, D. 1988. "A theory of floating quantifiers and its corollaries for constituent structure". *Linguistic Inquiry* 19: 425-449.
- Stockwell, R., Schachter, P. and Partee, B. 1973. *The Major Syntactic Structures of English*. New York: Holt, Reinhart and Winston.
- Tenny, C. 1987. Grammatical aspect and affectedness. Ph.D. dissertation, MIT.
- Thorne, J. 1966. "English imperative sentences". *Journal of Linguistics* 2: 69-78.
- Ukaji, M. 1978. *Imperative Sentences in Early Modern English*. Tokyo: Kaitakusha.
- Visser, F. 1963-1973. *An Historical Syntax of the English Language*. (3 parts, 4 vols.). Leiden: E.C. Brill.
- Zanuttini, R. 1991. Syntactic properties of sentential negation: A comparative study of Romance languages. Ph.D. dissertation, University of Pennsylvania.
- Zanuttini, R. 1994. "Speculations on negative imperatives". *Rivista di Linguistica* 6: 119-141.
- Zanuttini, R. 1997. *Negation and Clausal Structure: A Comparative Study of Romance Languages*. Oxford: Oxford University Press.
- Zhang, S. 1990. The status of imperatives in theories of grammar. Ph.D. dissertation, University of Arizona.
- Zubizarreta, M.-L. 1995. *Word Order, Prosody and Focus*. Cambridge, Mass., MIT Press.
- Zwicky, A. and Pullum, K. 1983. "Cliticization vs. inflection: English *n't*". *Language* 59: 502-513.